

P-282

Modular XYZ Piezo Flexure Nanopositioning Stages

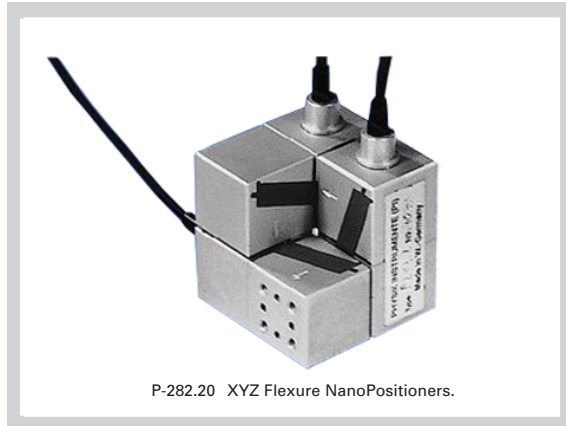

- Cost-Effective XYZ Positioning
- Travel Ranges to 50 x 50 x 50 μm

P-282 3-axis piezo-driven, flexure-guided stages are based on combinations of P-280 stages sold together with assembly hardware (see page 2-30 for specifications and drawing below for assembly).

P-282 multi-axis stages are available in three different sizes, with travel ranges of 30, 50 and 100 μm .

P-282 XYZ stages are easily assembled by bolting the bottom stage (X) down first and attaching the second (Y) and third (Z) stages successively. P-281 stages can be mounted as XZ and XY combinations.

Notes

See the "Piezo Drivers & Nanopositioning Controllers" section, p. 6-8 ff. for our comprehensive line of low-noise control electronics.

See the "Selection Guide" on p. 2-14 ff. for comparison with other nanopositioning systems.

Technical Data

Model	P-282.20
Axes	X,Y,Z
Displacement	50 x 50 x 50 μm
Consists of	3 x P-280.20
Cable Position*	A + B + C

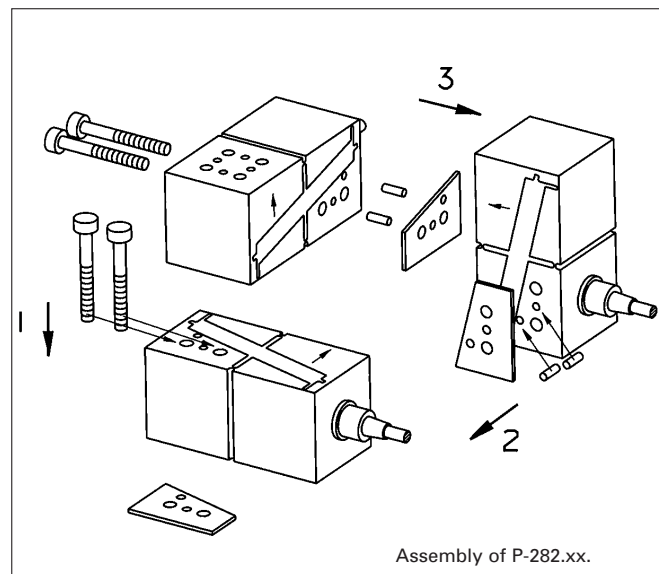
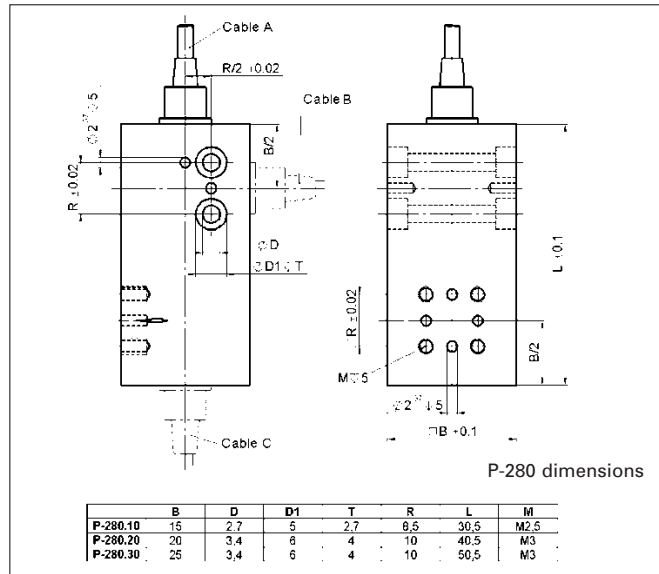

Piezo Actuators

Nanopositioning & Scanning Systems

Active Optics / Steering Mirrors

Tutorial: Piezo-electrics in Positioning

Capacitive Position Sensors

Piezo Drivers & Nanopositioning Controllers

Hexapods / Micropositioning

Photonics Alignment Solutions

Motion Controllers

Ceramic Linear Motors & Stages

Index

E-463

HVPZT Piezo Amplifier, 3 Channels



E-463.00

- 3 Independent Channels
- 3 x 6 W Peak Power
- 3 LED Voltage Displays
- Output Voltage Range 0 to -1500 V

The E-463.00 is a bench-top piezo driver for high-voltage PZTs. It contains three independent low-noise, 4-quadrant amplifiers that can output and sink a peak current of 4 mA and an average current of 3 mA each. The E-463.00 can be operated in two ways:

I. Manual Control:

Output voltage for each channel can be set by a 10-turn DC-

offset potentiometer in the range of 0 to -1000 V.

II. External Control:

Output voltage is controlled by an analog signal applied to the BNC inputs, ranging from 0 to 10 V. Multiplying by the gain factor of -150, an output voltage range of 0 to -1500 V results. The DC-offset potentiometer adds a DC bias to the input, allowing continuous shifting of

Ordering Information

E-463.00
HVPZT Amplifier, 3 Channels,
Bench-Top

Ask about custom designs!

the input range between 0 V to +10 V and -6.66 V to 3.33 V (see page 6-52).

Three 3½-digit LED displays show the output voltage of each individual channel. For frequency response with selected HVPZTs, see graph below.

For computer-controlled closed-loop positioning electronics, refer to the E-500 system starting on page 6-18.

Technical Data

Models	E-463.00
Function	Power amplifier
Channels	3
Maximum output power	6 W / channel (see page 6-52)
Peak output current <5 ms	4 mA / channel
Average output current >5 ms	2 mA / channel
Current limitation	Short-circuit proof
Voltage gain	-150 ±1
Polarity	Negative
Control input voltage	0 to +10 V
Output voltage	0 to -1500 V
DC-offset setting	0 to -1000 V at output with 10-turn pot.
Input impedance	1 MΩ
Display	3 x 3½-digits, LED
Control input sockets	3 x BNC
PZT voltage output sockets	3 x LEMO ERA.0A.250.CTL
Dimensions	236 x 88 x 273 mm + handles (see page 6-10)
Weight	4.3 kg
Operating voltage	90-120 / 220-240 VAC, 50-60 Hz (linear P/S)

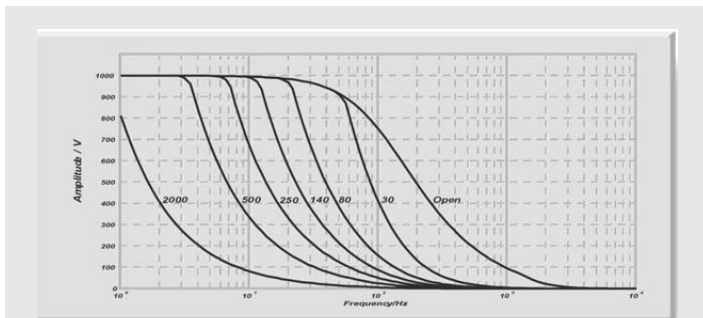

E-463, frequency response with various PZT loads. Values shown are capacitance in nF, measured in actual PZT.